



TOYOTA LC300

PRODUCTION DATE: OCTOBER 2021 ONWARDS

FITTING INSTRUCTIONS FOR:

ACCESSORY PART NUMBER: K30000

REAR BAR

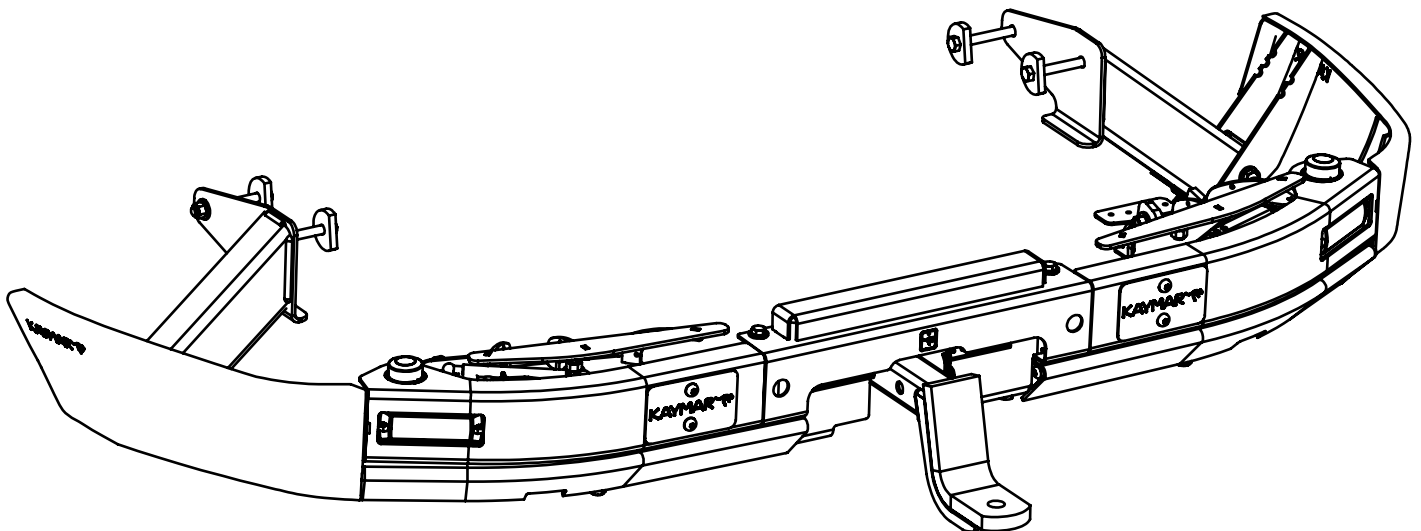

Use QR code to watch full installation video

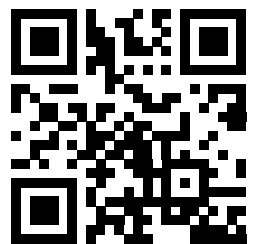

CAUTION

Ensure correct tools & appropriate PPE are used whilst installing this accessory

CARE INSTRUCTIONS

Wash with regular car wash products.
Regularly check bolt torque settings.

INSTALLATION TIME

Approximately 4-6 Hrs (guide only).

KIT CONTENTS

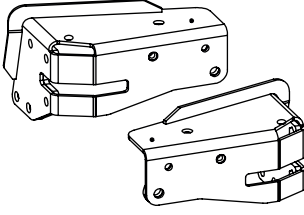
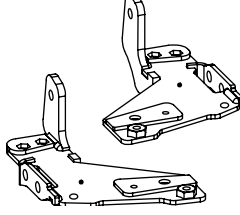
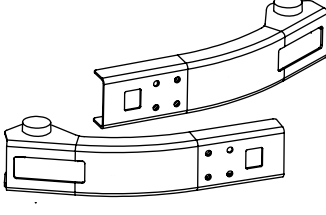
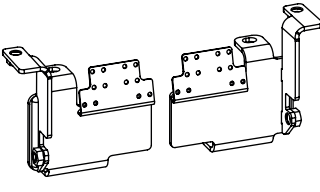
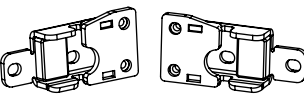
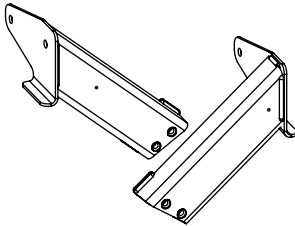
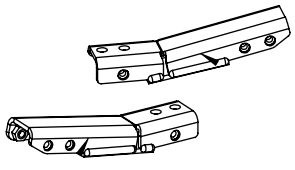
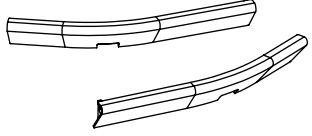
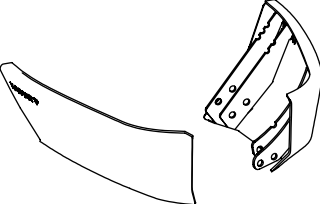
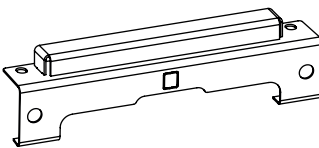
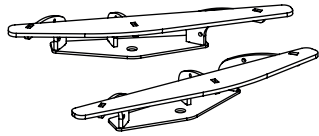
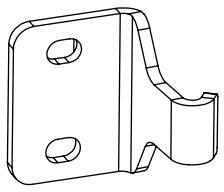
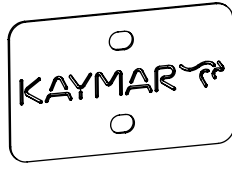
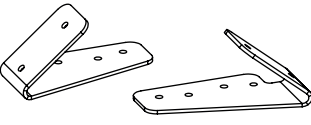
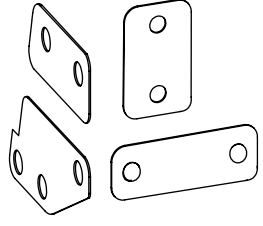
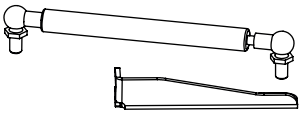
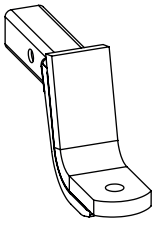
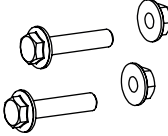
<p>1 Fitting Instructions</p>  <p>x1</p>	<p>2 Upper Mount - LH & RH</p>  <p>x1</p>	<p>3 Lower Mount - LH & RH</p>  <p>x1</p>	<p>4 Swing Arm Assy - LH & RH</p>  <p>x1</p>
<p>5 Inner Mount - LH & RH</p>  <p>x1</p>	<p>6 Catch - LH & RH</p>  <p>x1</p>	<p>7 Front Wing Mount - LH & RH</p>  <p>x1</p>	<p>8 Rear Wing Mount - LH & RH</p>  <p>x1</p>
<p>9 Lower Lip - LH & RH</p>  <p>x1</p>	<p>10 Wing - LH & RH</p>  <p>x1</p>	<p>11 Centre Panel</p>  <p>x1</p>	<p>12 Step Support - LH & RH</p>  <p>x2</p>
<p>13 Latch</p>  <p>x2</p>	<p>14 Cover Panel</p>  <p>x2</p>	<p>15 Mud Flap Support - LH & RH</p>  <p>x1</p>	<p>16 Shims</p>  <p>REFER PARTS LIST</p>
<p>17 Gas strut & lock - LH & RH</p>  <p>x1</p>	<p>18 TBM</p>  <p>x1</p>	<p>19 Fasteners</p>  <p>REFER PARTS LIST</p>	

 CHECK THAT THE CONTENTS OF THE KIT ARE COMPLETE & UNDAMAGED PRIOR TO FITMENT.

 IF ANY CONTENTS OF THE KIT ARE INCOMPLETE OR DAMAGED THEY MUST BE REPLACED USING SPECIFIED ACCESSORY COMPONENTS.

REAR BAR ASSEMBLY

REFER NEXT PAGE FOR PARTS LIST

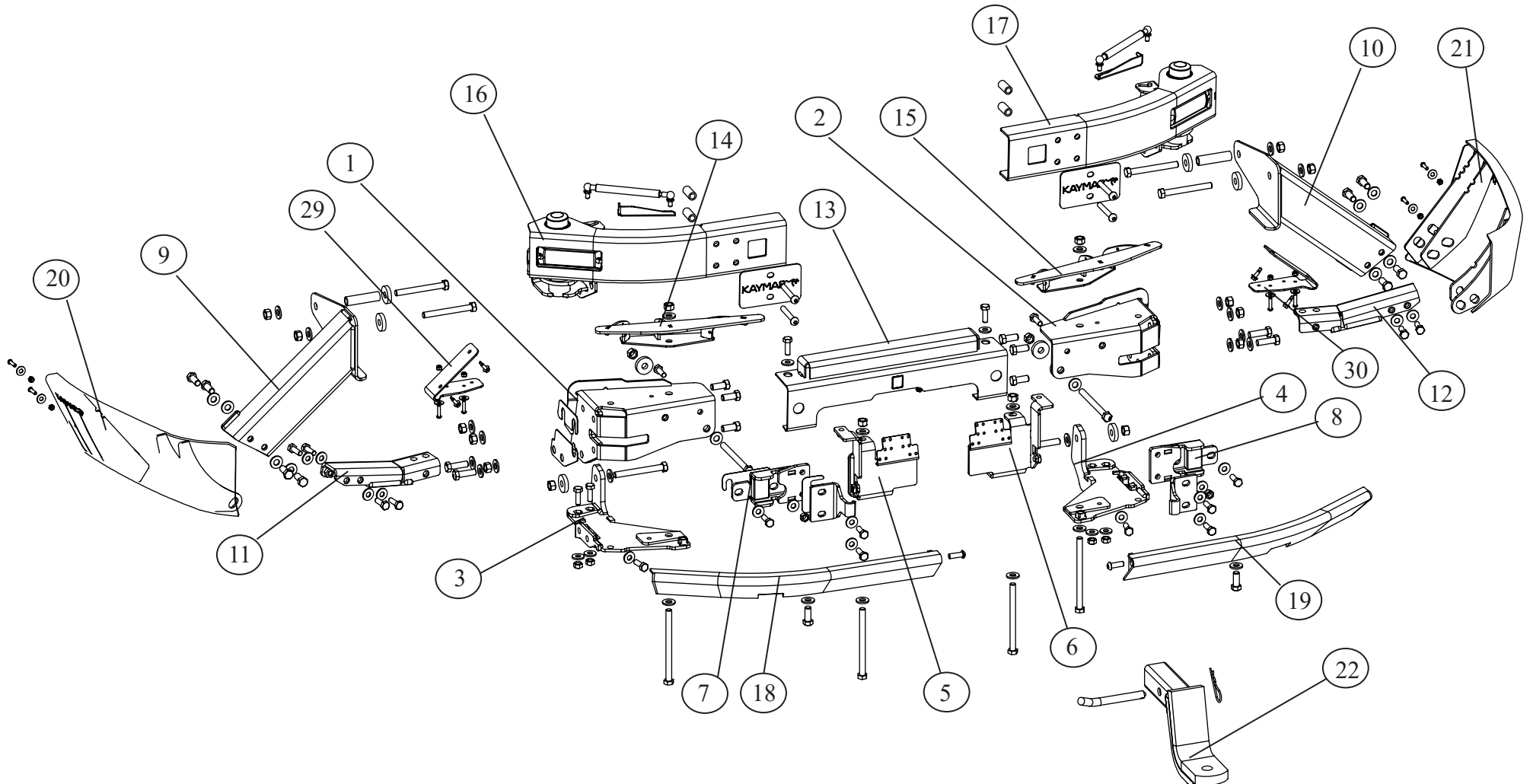

REAR BAR ASSEMBLY

PARTS LIST

Check contents of kit before commencing & report any discrepancies.

MAIN ASSEMBLIES

ITEM NO.	DESCRIPTION	QTY.
1	UPPER MOUNT BRACKET - LH	1
2	UPPER MOUNT BRACKET - RH	1
3	LOWER MOUNT BRACKET - LH	1
4	LOWER MOUNT BRACKET - RH	1
5	INNER MOUNT BRACKET - LH	1
6	INNER MOUNT BRACKET - RH	1
7	CATCH ASSY - LH	1
8	CATCH ASSY - RH	1
9	FORWARD WING MOUNT - LH	1
10	FORWARD WING MOUNT - RH	1
11	REAR WING MOUNT - LH	1
12	REAR WING MOUNT - RH	1
13	CENTRE PANEL	1
14	STEP SUPPORT - LH	1
15	STEP SUPPORT - RH	1
16	SWING ARM ASSEMBLY - LH	1
17	SWING ARM ASSEMBLY - RH	1
18	LOWER LIP - LH	1
19	LOWER LIP - RH	1
20	WING - LH	1
21	WING - RH	1
22	TBM	1

COMPONENTS

ITEM NO.	DESCRIPTION	QTY.
23	LATCH HOOK	2
24	PIVOT SHIM - UPPER	4
25	PIVOT SHIM - LOWER	2
26	CATCH SHIM	6
27	LATCH SHIM	6
28	REAR COVER PLATE	2
29	MUD FLAP SUPPORT - LH	1
30	MUD FLAP SUPPORT - RH	1
31	GAS STRUT & STOP - LH	1
32	GAS STRUT & STOP - RH	1
33	LC300 PATCH LOOM	1
34	UNIVERSAL WIRING LOOM	1
35	TOW RATING LABEL	1
36	REFLECTIVE TRIANGLE	1
37	RED ADHESIVE REFLECTOR	2
38	ADHESIVE FOAM - 10mm THICK	200mm
39	PULL PIN	1
40	R CLIP	1
41	SWING ARM CRUSH TUBE	4
42	CABLE TIES	15
43	SUPER GLUE	1
44	CUT TEMPLATE	1
45	DOOR LABEL	1

FASTENERS

ITEM NO.	DESCRIPTION	QTY.
46	BOLT M12 X 160mm	2
47	BOLT M12 X 150mm - BLACK	2
48	BOLT M12 X 140	2
49	BOLT M12 X 110	6
50	BOLT M12 X 40	4
51	BOLT M12 X 30	14
52	BOLT M12 x 30 - BLACK	2
53	NUT M12	18
54	BEARING WASHER M12	8
55	WING CRUSH TUBE	4
56	WASHER M12 - STD	36
57	BOLT M10 X 30	24
58	BUTTON HEAD BOLT M10 X 30 - BLACK	2
59	BUTTON HEAD BOLT M10 X 70	4
60	NUT M10	6
61	WASHER M10	24
62	BUTTON HEAD BOLT M6 X 20	8
63	NYLOC NUT M6	8
64	BUTTON HEAD BOLT M8 X 25	1
65	BOLT M4 X 16	2
66	NYLOC NUT M4	2
67	TEX SCREW 14G-24	4
68	ADHESIVE FOAM - 5mm THICK	1m
69	REAR CRUSH TUBE	2

NOTE: THE FASTENERS ARE SUPPLIED IN 3 BAGS. BAG 1 IS FOR STEPS 1-23, BAG 2 IS FOR STEPS 24-32 & BAG 3 IS FOR STEPS 33-58

STEP 1

- Remove LH rear wheel arch trim by removing 1x large scrivet, 1x small scrivet & 1x 4mm hex drive screw.
- Gently lever the trim away from the body starting at the rear door edge, to un-clip the 7x body clips.
- Repeat for RH side.

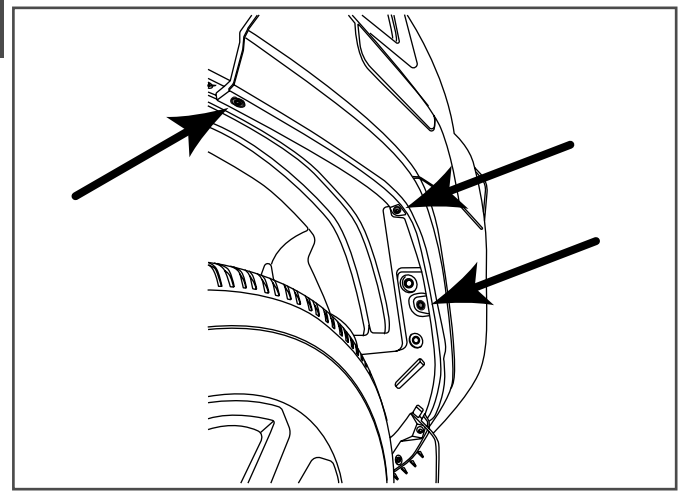

STEP 2

- Remove LH rear mud flap by removing 1x scrivet and 3x 4mm hex drive screws.
- Repeat for RH side.

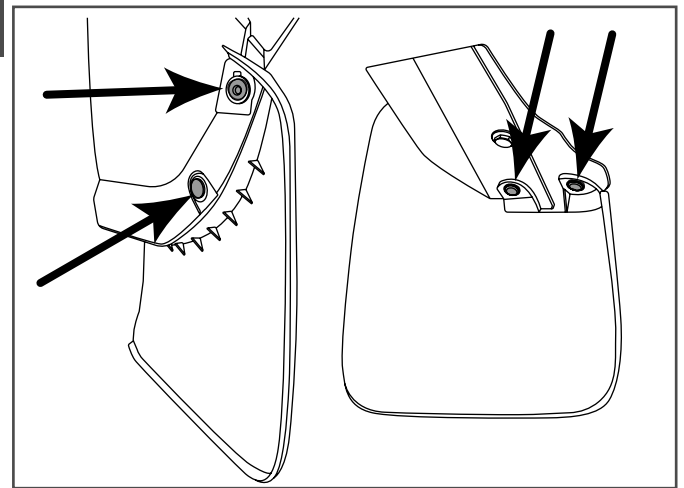

STEP 3

- Remove LH rear inner wheel lining by removing 2x scrivet and 1x 10mm hex head screw.
- Repeat for RH side.

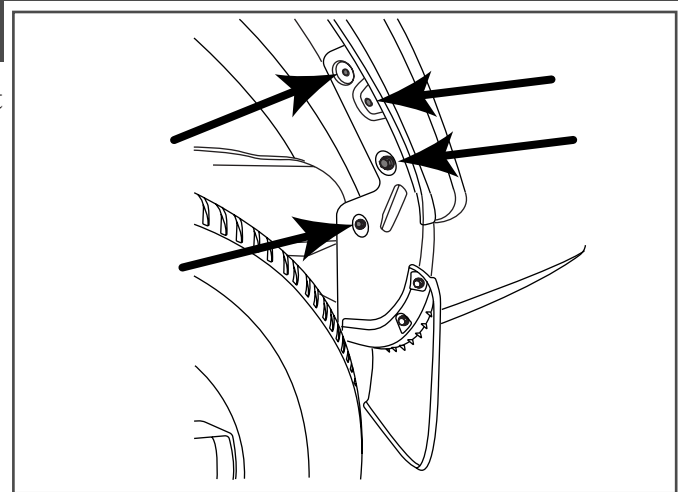

STEP 4

- Open tailgate and remove LH taillight cover by gently levering the outboard side first.
- Repeat for RH side.

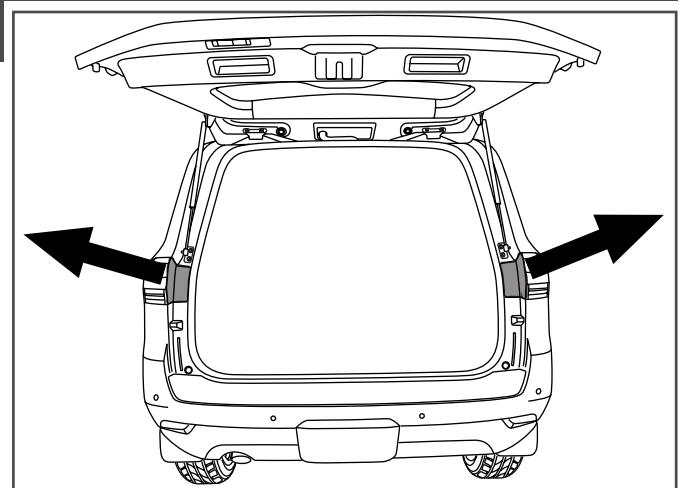

STEP 5

- Remove the spare wheel lowering rod cover.
- Remove rear step tread by levering up the rear edge first, then pull up and rearward from the forward side.

NOTE: Outboard pieces do not need to be removed, but care should be taken to avoid scratching these when removing & installing the step tread.

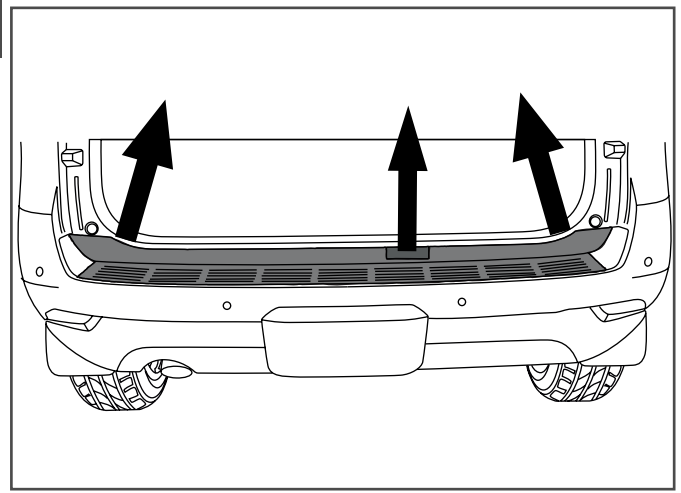

STEP 6

- Unplug the bumper loom accessed through the cutout on the RH upper side of the bumper.

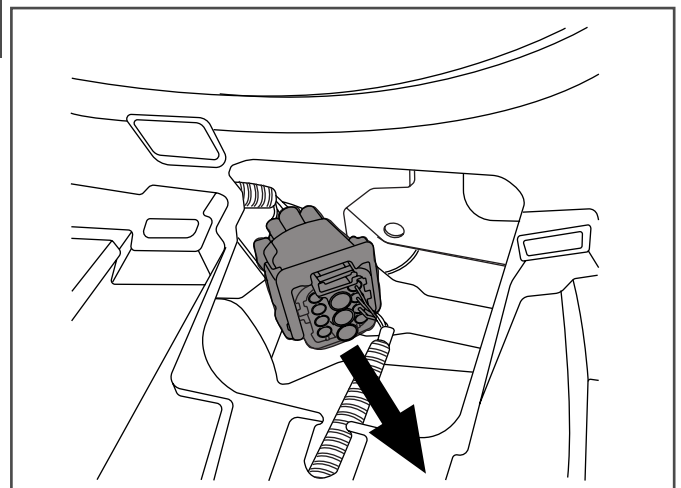

STEP 7

- Remove rear bumper by removing:
 - Scrivet on upper forward corner of LH & RH sides
 - 10mm head screw next to tail light on LH & RH sides
 - 5x 10mm head bolt behind step tread
 - 10mm head screw/bolt along lower rear edge (4 per side)
- Gently pry bumper away from body along sides and lift clear of vehicle.

NOTE: Store bumper in a safe location that will not scratch/damage it, such as a panel stand.

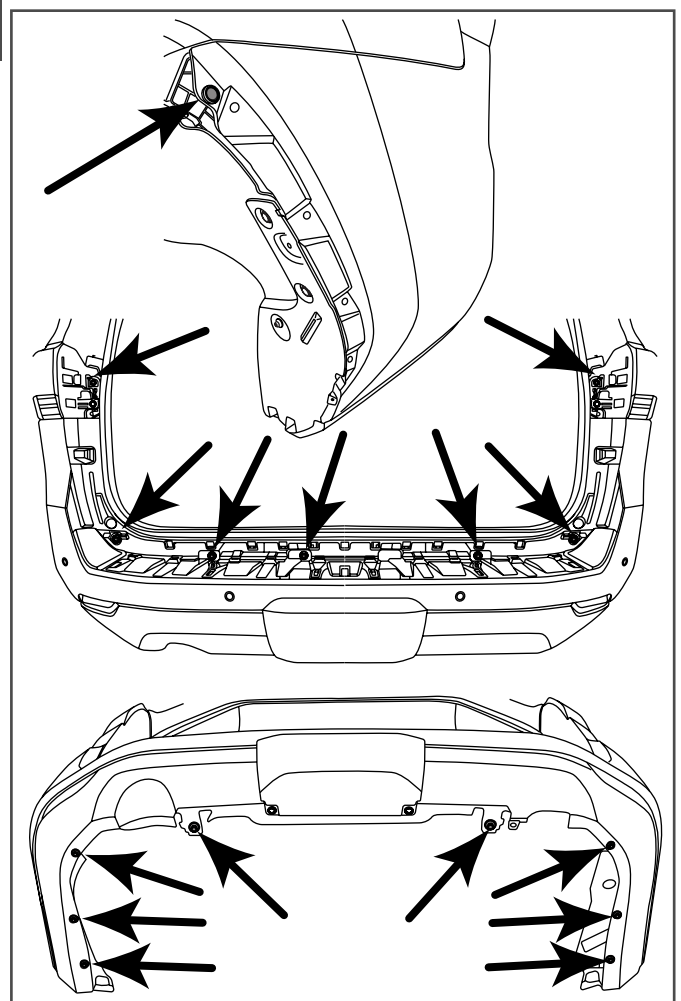

STEP 8

- Lift off and discard foam step support.

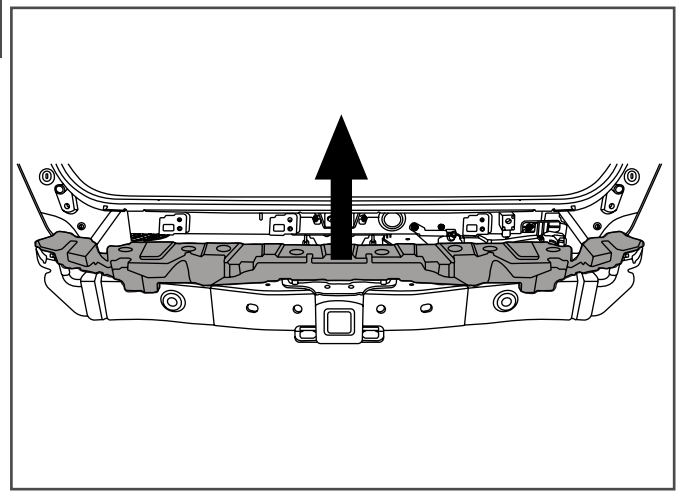

STEP 9

- Remove & discard LH rear lower cover by removing 2x 10mm head screws. Squeeze the inboard side of the plastic threaded clips to release the cover.
- Repeat for RH side.

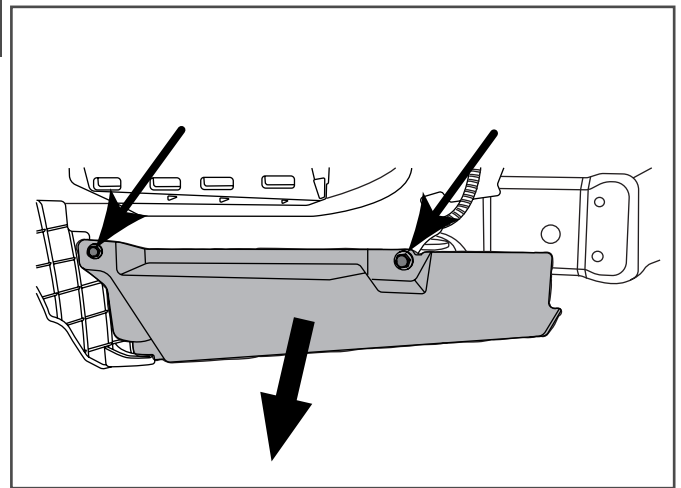

STEP 10

- Remove & discard RH lower bumper mount by removing 1x 12mm head bolt.
- Repeat for LH side.
- Remove & discard shipping hook by removing 2x 16mm head bolts.

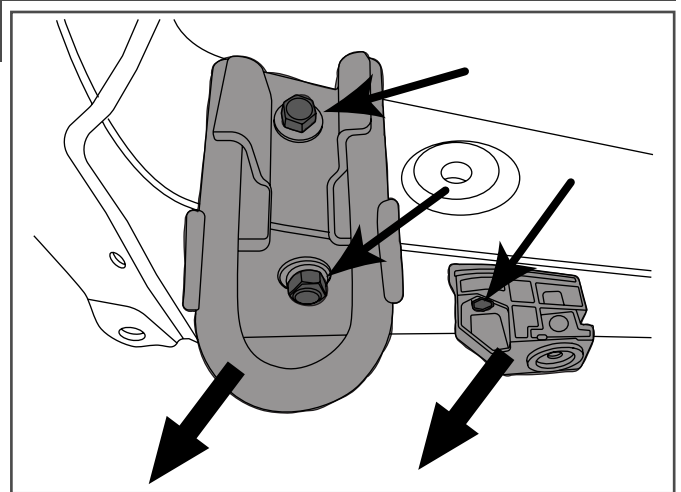

STEP 11

- Remove wiring loom holder on RH side of chassis by removing the 10mm head bolt & un-clipping from top of chassis.
- Remove loom from holder by un-clipping the lid.
- Discard plastic holder & bolt.
- Remove & replace 10mm head bolt on the earth wire with supplied M8x25 button head bolt, ITEM 64.

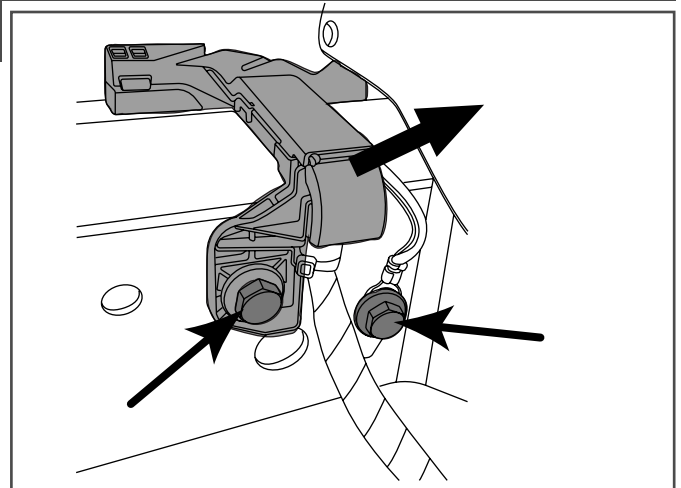

STEP 12

- Release wiring loom from RH body bracket by un-clipping 4x loom connections & removing 10mm bolt from earth wire.
- Un-bolt wiring loom bracket from body by removing 1x 10mm head bolt.

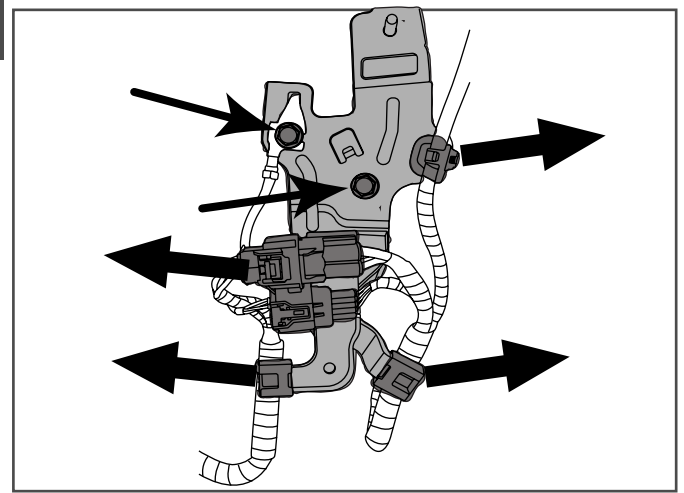

STEP 13

- Cut off the lower part of loom bracket as shown and seal the cut surface of the upper part with a suitable paint.
- Re-install upper portion of bracket to RH side of body with original 10mm head bolt from step 12.

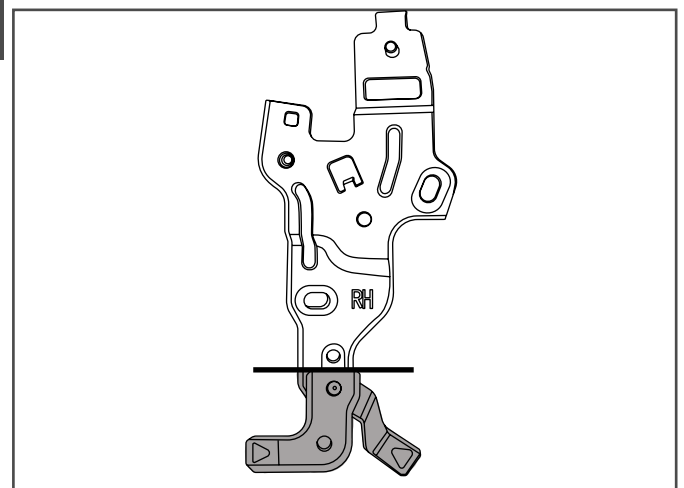

STEP 14

- Re-attach earth lead to bracket with original 10mm head bolt from step 11.
- Return upper RH loom clip to original position.
- Using supplied cable ties, cable tie loom, loom plugs & lower loom as shown

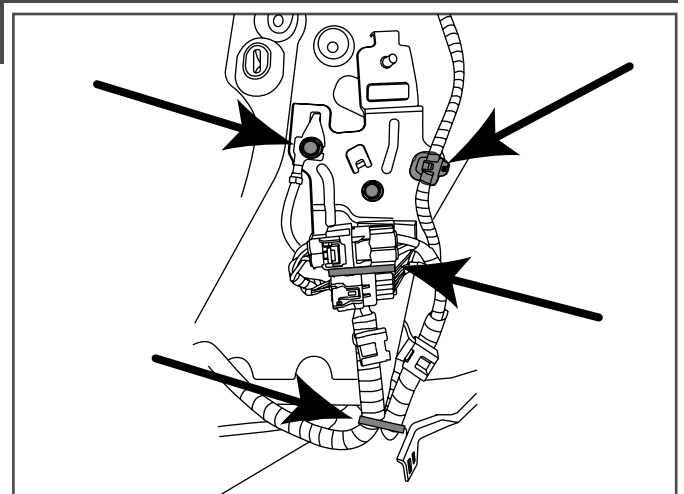

STEP 15

- Drill out 2x holes on upper surface of chassis, as shown, with 12.5mm (or 1/2") drill bit. De-burr and seal the cut surface with a suitable paint.

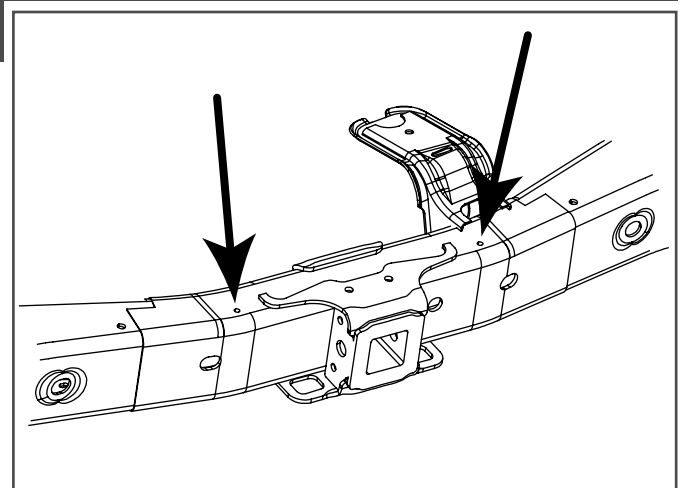

STEP 16

- Insert 3x M12x30 bolts and 1x M10x30 bolt, ITEMS 51 & 57 into LH upper main bracket, ITEM 1, as shown.
- Insert crush tube, ITEM 69 into chassis from rear and place bracket over the top.
- Install 1x M12x140 bolt, 1x STD & 1x M12 bearing washer & 1x M12 nut, ITEMS 48, 57, 54 & 53 through hole shown. Do not tighten bolt yet.

NOTE: Bolt head to be installed on rear surface.

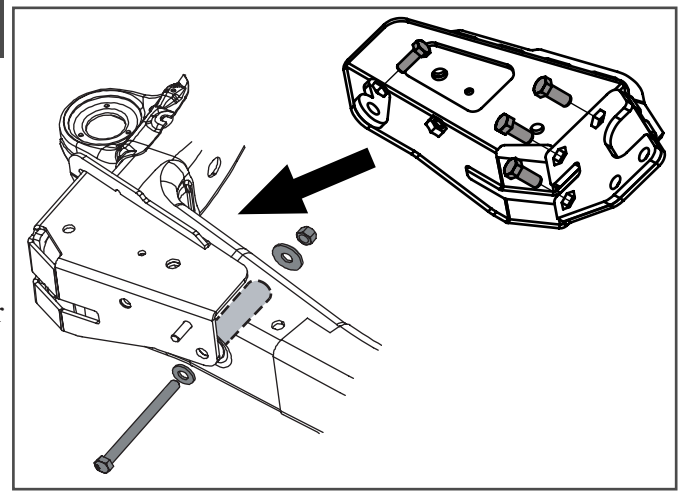

STEP 17

- Insert 2x M10 bolts, ITEM 57 into LH lower bracket, ITEM 3, as shown and offer bracket to bottom of the LH rear corner of the chassis. Locate using 1x M12x160 bolt & 1x M12 washer, ITEMS 46 & 56. Bolt head should be at the bottom.
- Position LH step support, ITEM 14, on top of LH upper bracket and secure items in position with 1x M12 washer & 1x M12 nut, ITEMS 56 & 53. Do not tighten bolt yet.

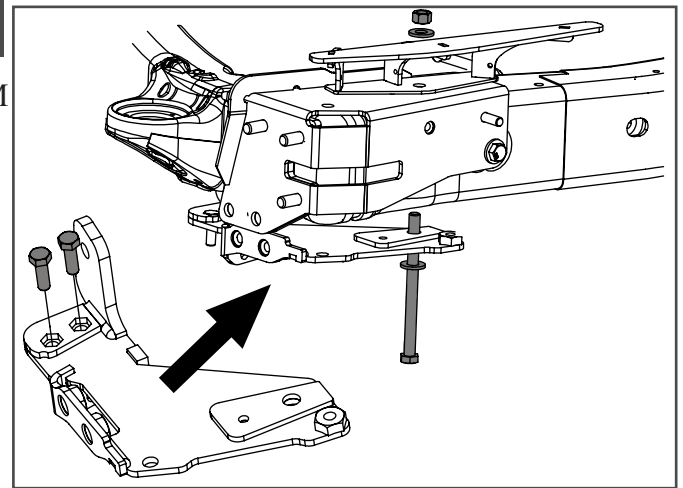

STEP 18

- Insert 1x M12x110 bolt & 1x M12 STD washer, ITEMS 49 & 56, through forward hole on lower bracket and through chassis.
- Install 1x M12 bearing washer & 1x M12 nut, ITEMS 54 & 53, on other side of chassis. Do not tighten bolt yet.

NOTE: In some circumstances body rubber may need to be removed to give access to assemble the nut & washer.

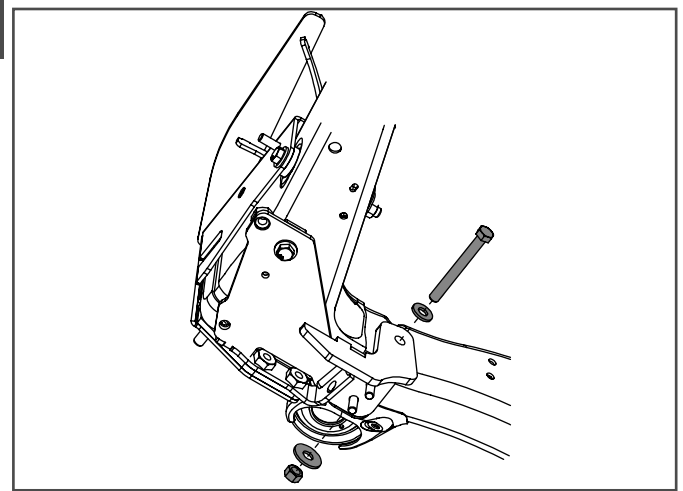

STEP 19

- Align upper and lower bracket to each other by using 2x M12x30 bolts & 2x M12 washers, ITEMS 51 & 56, through lower mounting holes.
- Ensure holes of both brackets visually align to each other to avoid the bolts rubbing against the sides of holes. When correct position is found, lightly tighten these 2 bolts.

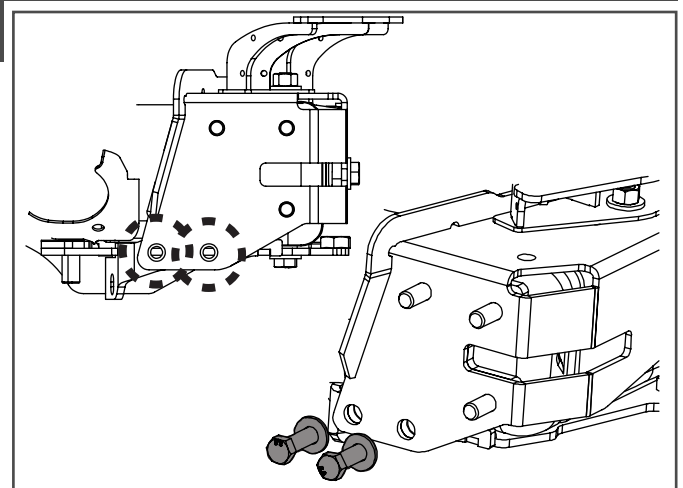

STEP 20

NOTE: If a Recovery Hook Kit has been purchased. Installation should be done now per provided instruction.

- Ensure the corner bracket is pushed hard into the chassis corner (a light tap with a rubber mallet can assist)
- Tighten M12 bolts to 90Nm in order shown.
- Cut a 330mm long piece of the 5mm thick adhesive foam, ITEM 68, and apply it to the top of the step support.

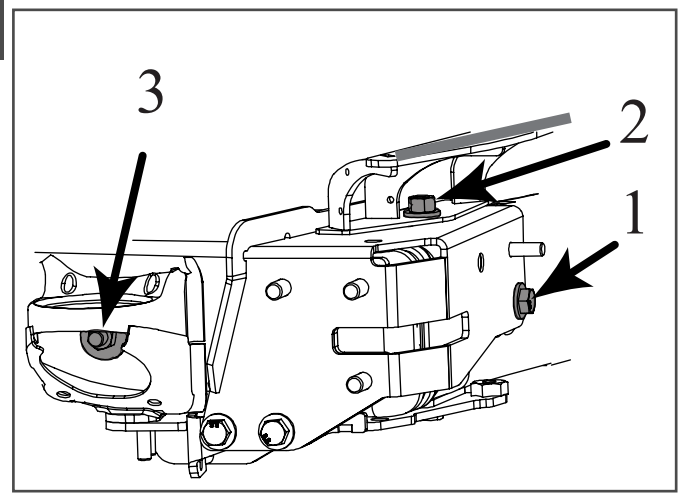

STEP 21

- Remove 2x M12 bolts & washers from step 19 & keep.
- Repeat steps 16-21 for RH corner brackets.
- Secure RH wiring loom to upper bracket gusset with 2x supplied cable ties, ITEM 42

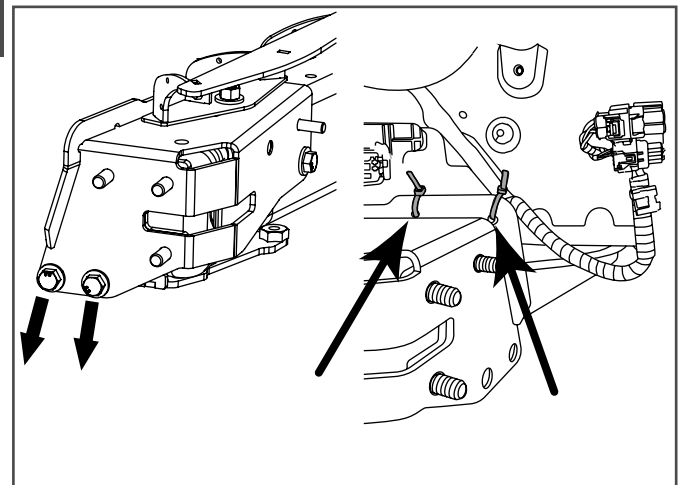

STEP 22

- Loosely install LH inboard mount, ITEM 5, to chassis with 1x black M12x150 bolt, 2x M12 washers & 1x M12 nut, ITEMS 47, 56 & 53.
- Adjust mount position so upper nut/washer is approximately central on the mount tab and lightly tighten the M12 bolt while pushing the mount firm against the rear chassis face.
- Repeat step for RH side mount.

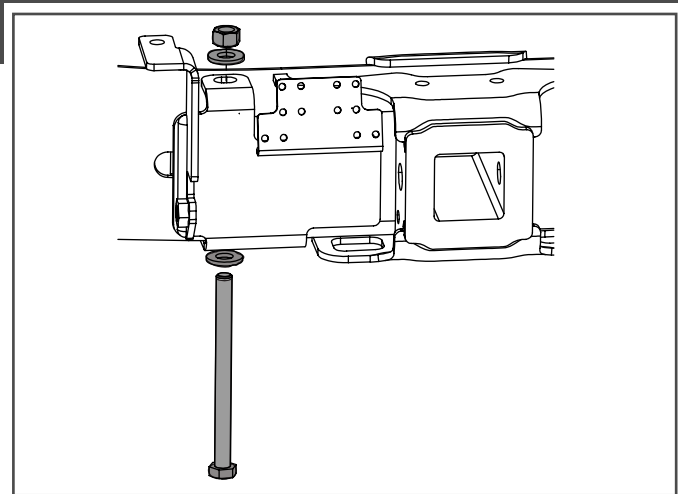

STEP 23

- Install centre plate, ITEM 13, over inboard mounts with 2x M10x30 bolts & 2x M10 washers, ITEMS 57 & 61.
- Align centre plate centrally over towbar receiver and push it back towards the chassis as far as possible. Lightly tighten the M10 bolts to hold this position.
- Cut a 330mm long piece of the 5mm thick adhesive foam, ITEM 68, and apply it to the top of the centre panel.

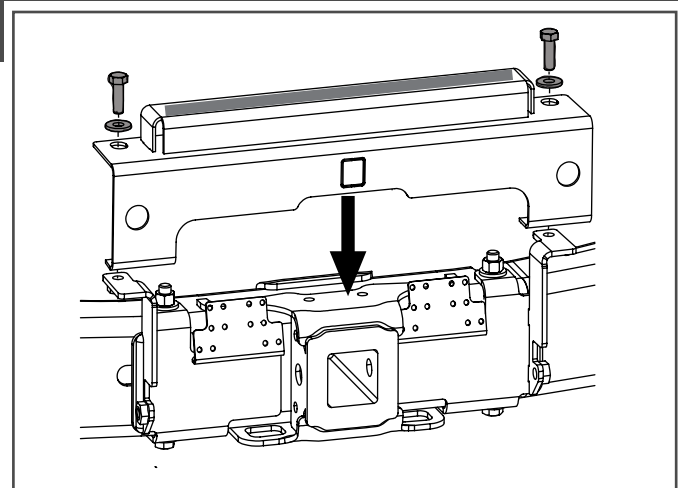

STEP 24

- Loosely install LH swing arm assembly, ITEM 16, as shown using 3x M12 nuts & 3x M12 washers in upper positions and 2x M12x40 bolts & 2x M12 washers in lower positions, ITEMS 53, 56 & 50
- While holding the swing arm assembly in the down and forward position, lightly tighten one of the upper bolts and 1 of the lower bolts to hold this position.

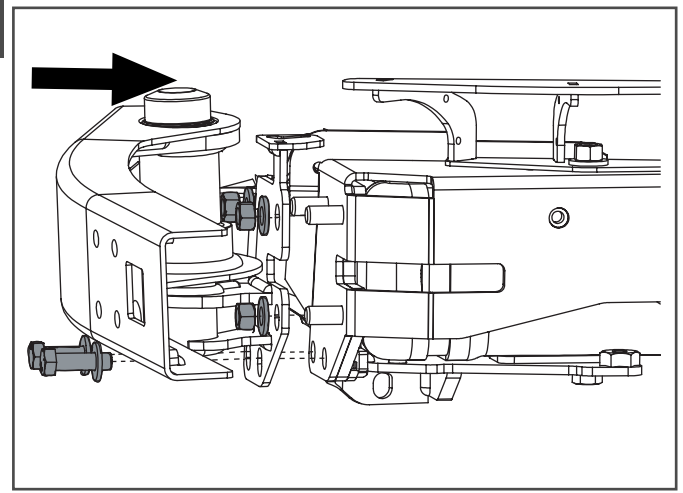

STEP 25

- Check alignment/position of swing arm relative to centre plate and adjust as follows:
 - First align the rear face of the swing arm with the rear face of the centre panel. Rotate the swing arm mount to correct this alignment.
 - With rear face alignment achieved, lightly tighten all fasteners and check the height and angle of the swing arm upper surface relative to the centre panel using a straight edge. If required remove the swing arm and re-assemble with a lower or upper shim, ITEMS 24 & 25, to correct swing arm angle. A lower shim will lower the inboard side, a upper shim will raise it. Up to 2 shims can be used in either position if required.
 - Once suitable alignment is achieved, tighten all 5 mount fasteners to 90Nm.
 - Repeat steps 24 & 25 for RH swing arm.

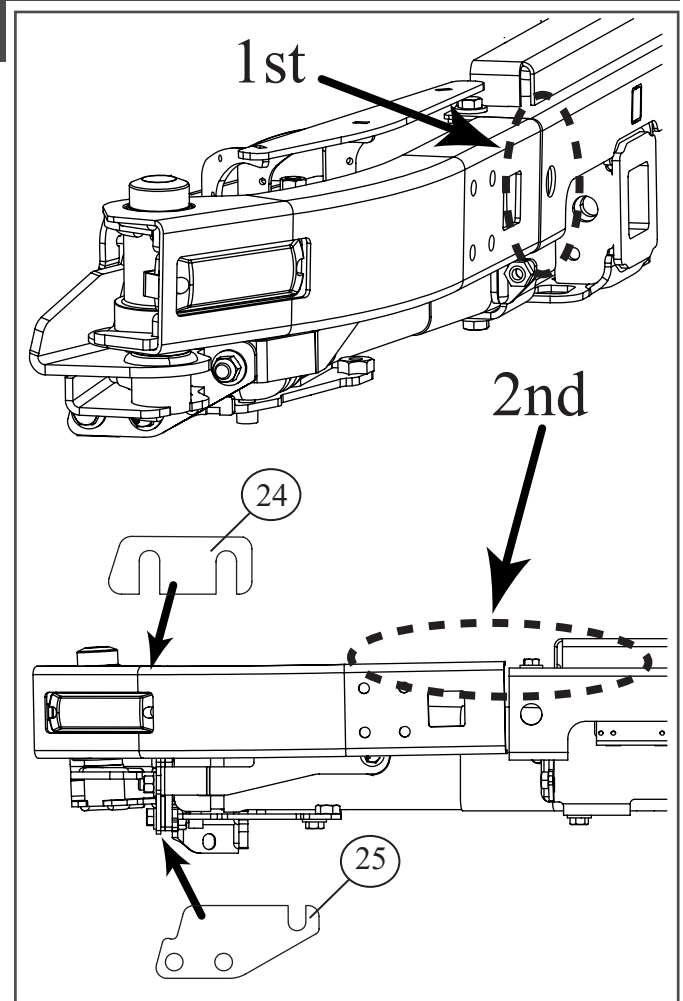

STEP 26

- Loosely install LH catch, ITEM 7, with 1x M10X30 bolt, 1x M10 nut and 2x M10 washers, ITEMS 57, 60 & 61.
- Close swing arm and check the stop position of swing arm rear face relative to the centre panel. The swing arm should stop 4-5mm further rearward than the centre panel to allow for rubber compression. If required remove catch and install shims, ITEM 26, until required offset is achieved.

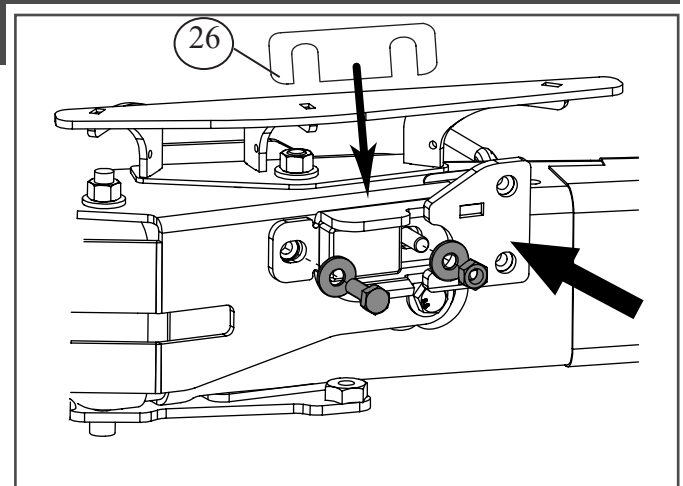

STEP 27

- Close the LH swing arm and check vertical position of locator relative to the catch. The locator should not be contacting the top or bottom guides.
- Close swing arm and check that 2x black M10 button head bolts, ITEM 58, fit through inboard holes. Remove bolts after correct position achieved. Tighten locator M10 bolt & nut to 60Nm. Repeat Steps 26 & 27 for RH side.

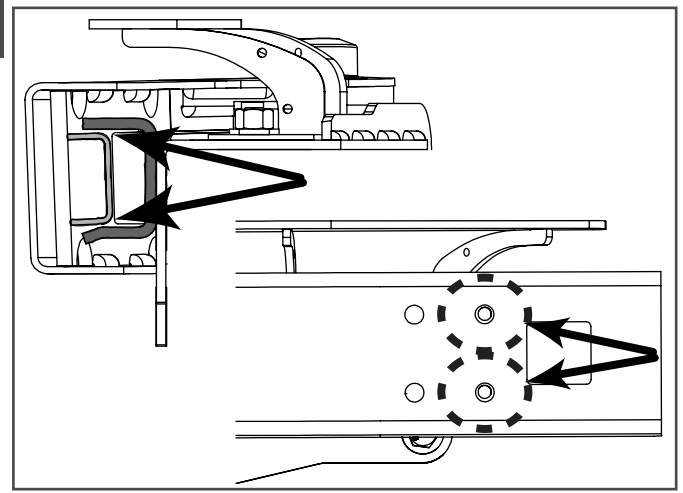

STEP 28

- Install the LH gas strut & stop latch, ITEM 31, onto the LH swing arm & pivot bracket as shown. Tighten the swing arm connection enough so that the stop latch movement is tight but possible. With the body side loosely assembled, close the swing arm door and reopen it quickly while guiding the gas strut along the tick shaped cutout to its final position. Tighten the body side connection and repeat for the RH side.

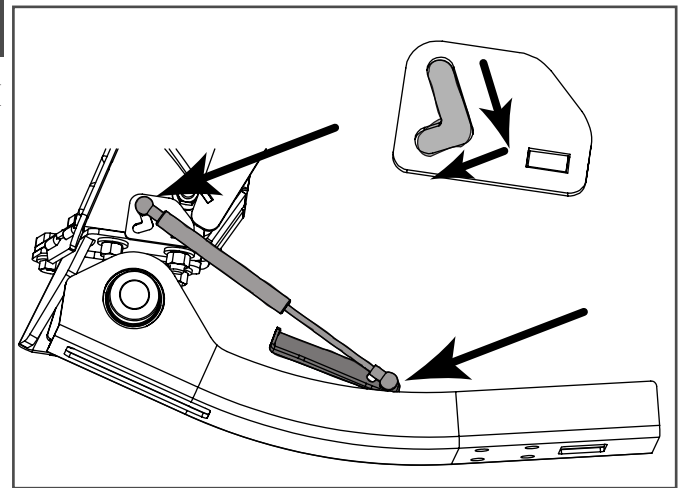

STEP 29

NOTE: Complete the following 2 steps if you have purchased a spare wheel carrier or jerry can holder.

- Install your optional spare wheel carrier or jerry can holder to the appropriate swing arm using the 4x M10 flange bolts & washer plate supplied with the carrier.
- Note: Washer plate to be installed under bolt heads on inside of swing arm. Torque bolts to 90Nm

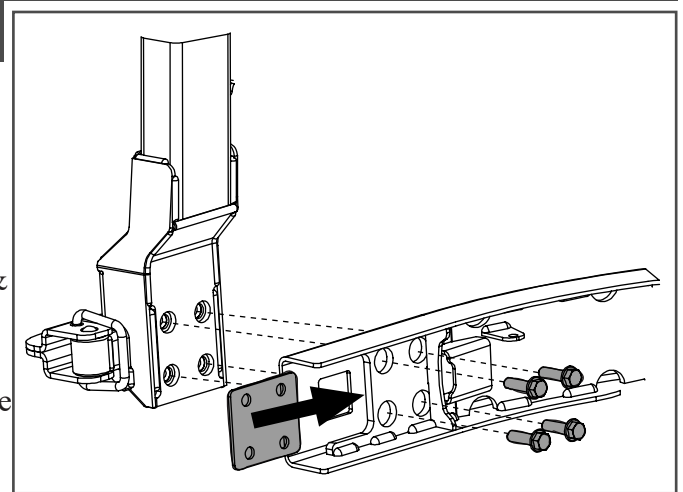

STEP 30

- Loosely install the latch using 2x M10X30 bolts & 2x M10 washers, ITEMS 57 & 61.
- Adjust the latch position so it does not foul on the swing arm opening, and is vertically aligned to the carrier handle.
- Lightly tighten the bolts and check the handle tension. If tension is too high, remove latch and add required amount of shims, ITEM 27. Tighten M10 bolts to 60Nm

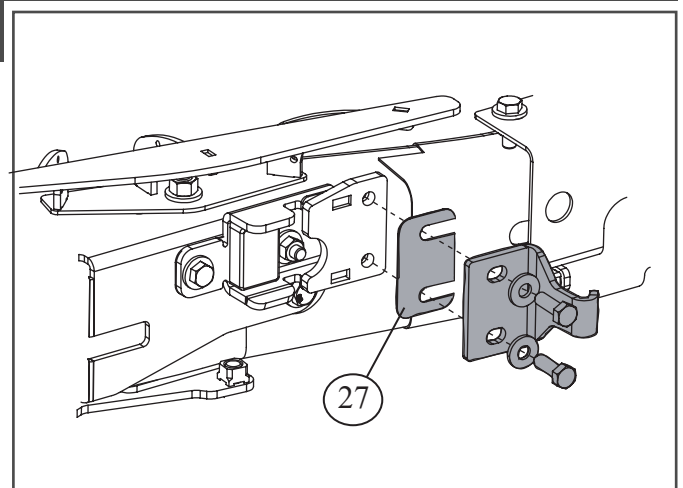

STEP 31

NOTE: Complete this step if you have **NOT** purchased a carrier/holder, or when not using them.

- Remove the latch & fasteners (shown in step 30) if previously fitted & store for future use.
- Secure the swing arm closed using 2x black M10 button head bolts, 2x spacer tubes and cover plate, ITEMS 58, 42 & 28, as shown. Tighten bolts to 60Nm.

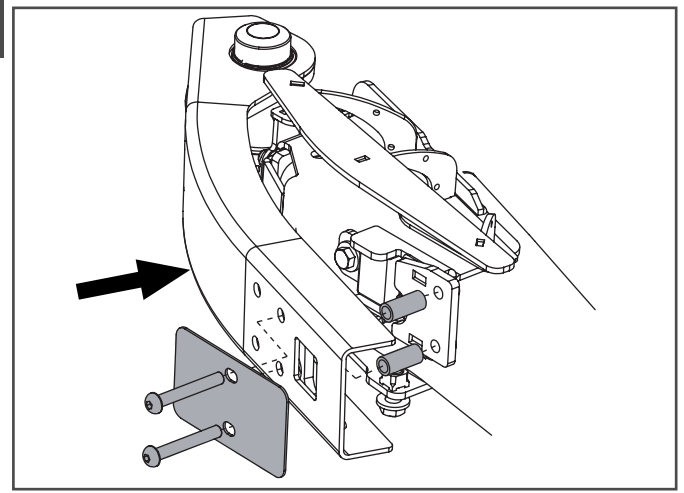

STEP 32

- Remove caps fitted to the factory loom plugs that are located above the muffler heat shield and connect the supplied LC300 patch loom, ITEM 33. NOTE: In some circumstances the heat shield may need to be removed to give access.
- Connect patch loom to the universal loom, ITEM 34, and route the universal loom out between the body & the LH upper chassis bracket.

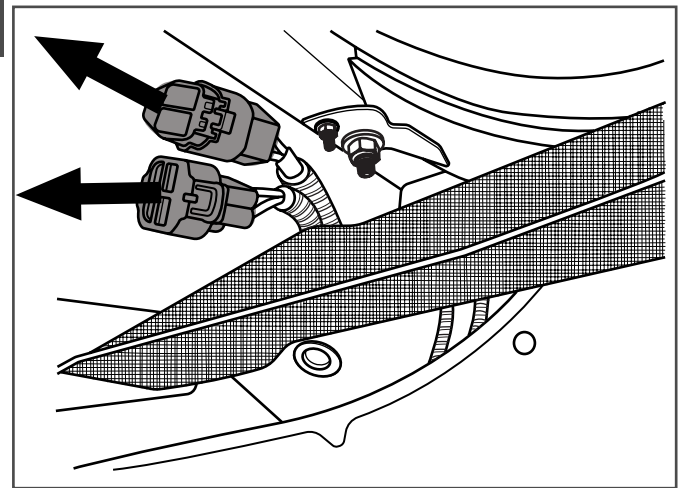

STEP 33

- Lay the universal loom across the top of the chassis and connect the RH combination lamp plug first. Route the loom behind the step supports
- Secure the combination lamp wiring to the swing arm hub, and secure the universal loom to the upper bracket gusset, next to the combination light plug, using cable ties, ITEM 42. Repeat for the LH combination lamp connection.

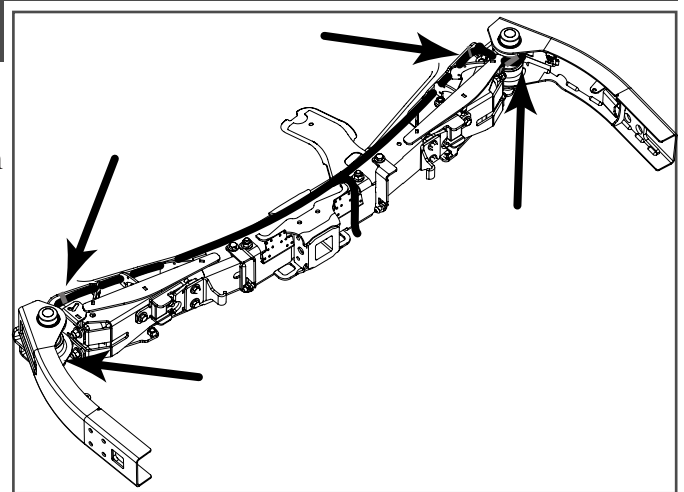

STEP 34

NOTE: Complete the following 3 steps if a carrier has been fitted that obscures the number plate

- A number plate light relocation kit should be purchased separately and installed to the appropriate side.
- For wheel carriers, secure the light to lock plate mount and route the wiring as shown. Secure the wiring with the supplied cable ties & pads.

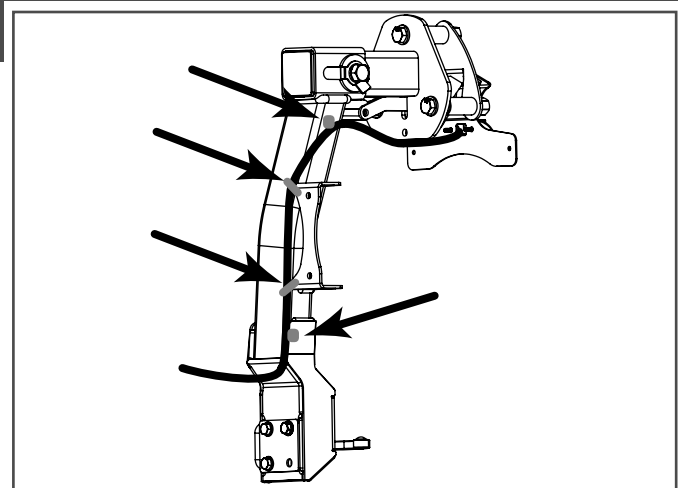

STEP 35

- For jerry can holders, secure the light to mount tab and route the wiring as shown. Secure the wiring with the supplied cable ties & pads.

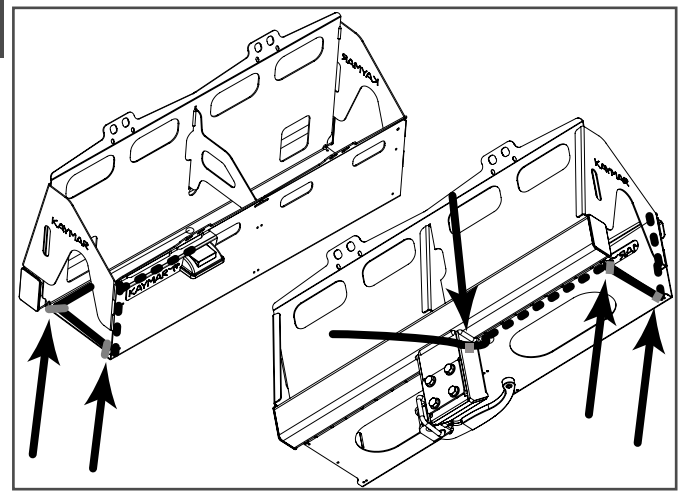

STEP 36

- Route the wiring through the notch in the swing arm and along the inside. Connect it to the universal loom and secure the wiring with the supplied cable ties & pads.

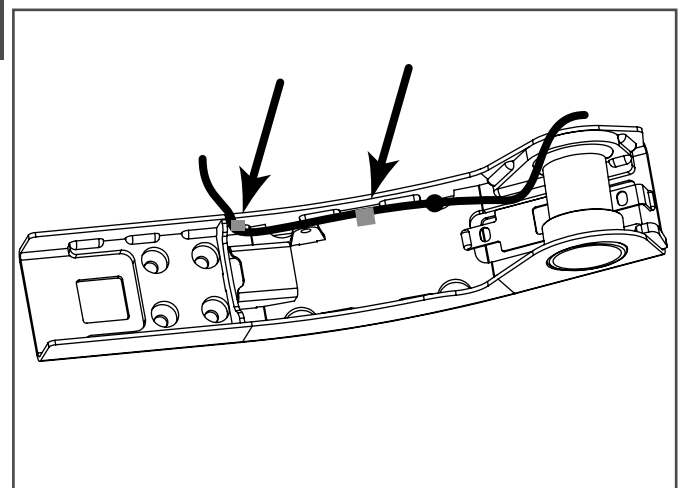

STEP 37

- The universal loom comes terminated, ready to install your chosen trailer plug. The rear bar is designed to accommodate a standard 7 or 12 pin plug.

- Install your chosen plug now, using the wiring diagram supplied with your plug.

REFER TRAILER PLUG
INSTRUCTIONS

STEP 38

- Remove the centre panel & RH inboard mount from step 21 & 22.

- Secure the trailer plug to the RH side inboard mount using 2x M4X16 bolts & 2x M4 nuts, ITEMS 65 & 66.

NOTE: If additional wiring is being installed such as Anderson plug, these should be installed now on the LH inboard bracket.

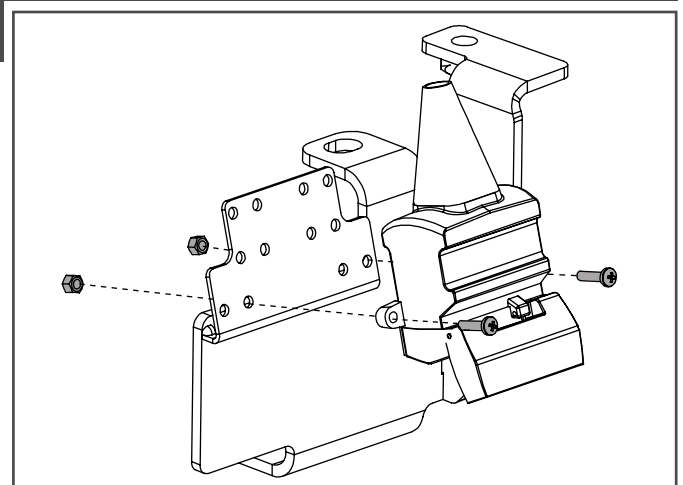

STEP 39

- From the inside of the bumper, unclip the park sensor loom from each of the park sensors
- Unclip the loom from the bumper and remove.
- With a sharp knife and/or side cutters, remove all the location clips from the loom as indicated.

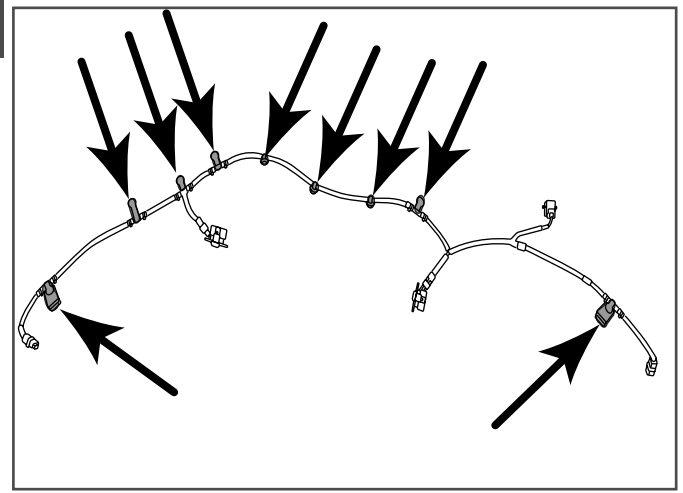

STEP 40

- Unclip the inboard park sensors from their carriers on the inside bumper surface. NOTE: Park sensors are handed and should be marked LH/RH to avoid changing their position.
- Gently pry the inboard green carriers off the bumper using a suitable scraper/screw driver and assemble back onto the removed park sensor. NOTE: Carriers have a top & bottom side and should be marked to maintain this.

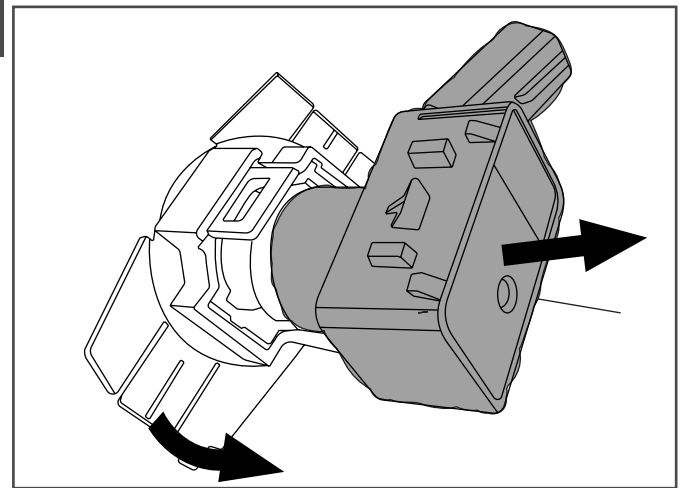

STEP 41

- Apply glue, ITEM 43 to the contact face of the park sensor carrier, being careful not to get glue onto the park sensor itself. Install the inboard park sensors to the inside face of centre panel on their appropriate sides with the plugs facing outboard. Apply firm pressure and hold for 1 minute. Trim the excess carrier material level with the edge of the centre panel using a sharp knife

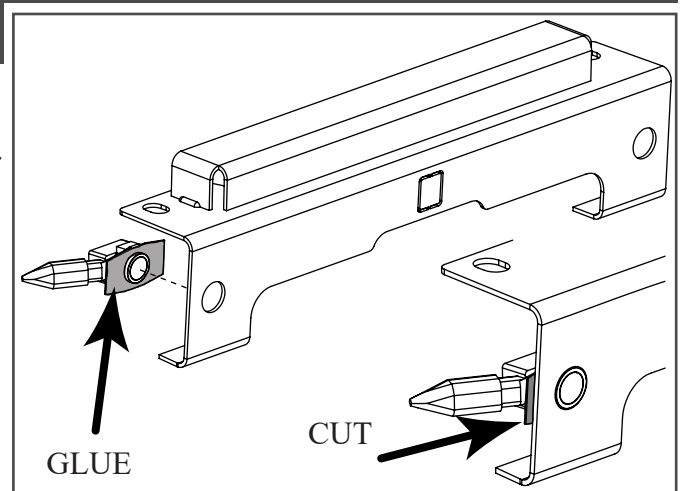

STEP 42

- Install the supplied load rating label, item 35, onto the chassis surface behind the LH swing arm.
- Re-Install the centre panel and inboard mounts per steps 21 & 22. Tighten M12 bolts to 90Nm
- With the swing arms latched or bolted shut, align the centre panel position with both swing arms and tighten the M10 bolts to 60Nm

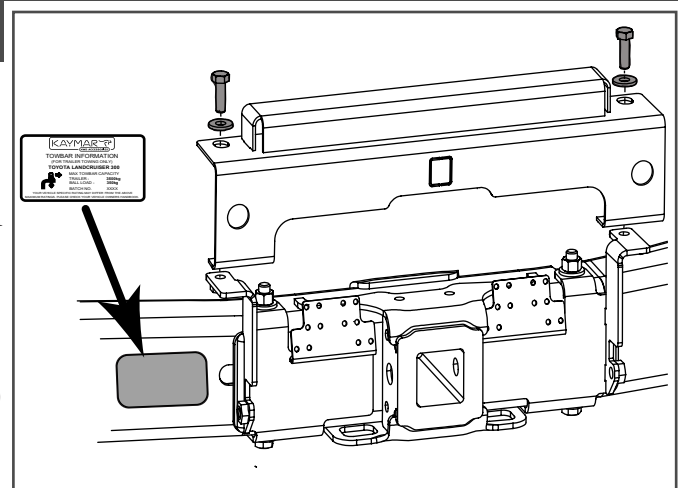

STEP 43

- Lay the park sensor loom across the top of the chassis behind the centre panel and under the step supports.
- Re-connect the main loom plug and inboard park sensors
- Secure looms with Cable ties as shown. There may be excess loom in the centre that will need to be secured

NOTE: Take care not to damage the outboard park sensor plugs if/when opening/closing the swing arms

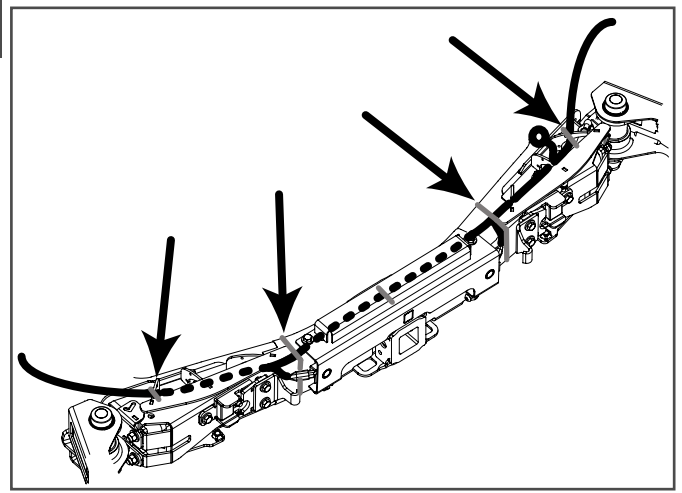

STEP 44

- Install LH lower lip, ITEM 18, using 1x black M12 bolt, 1x M12 washer and 1x black M10 button head bolt, ITEM 52, 56 & 58.
- Use M12 mount to adjust the forward & backward position. Use M10 mount to align angle of lip to best match swing arm. Tighten M10 bolt to 60Nm & M12 bolt to 90Nm.
- Repeat for RH side.

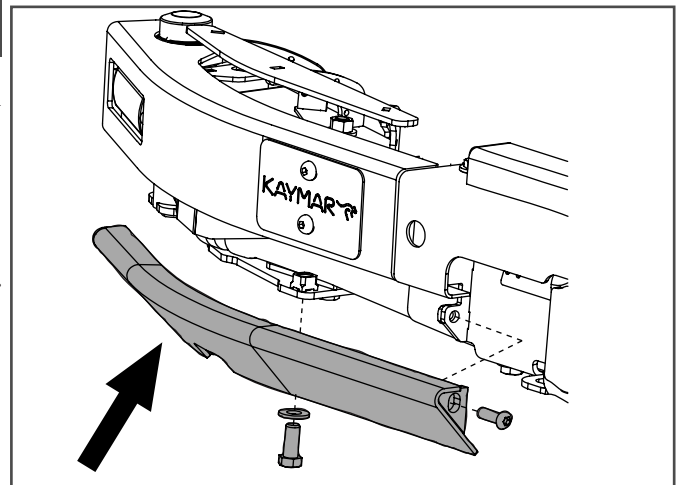

STEP 45

- Loosely install LH Forward wing mount, ITEM 9, using 2x M12X110 bolts, 2x M12 STD washers, 2x M12 bearing washers, 1x crush tube & 2x M12 nuts, ITEMS 49, 56, 54 & 53, as shown.

NOTE: The crush tube is installed on the forward mount.

- Ensure the mount is sitting hard upward against the bottom of chassis and lightly tighten bolts to hold this position.

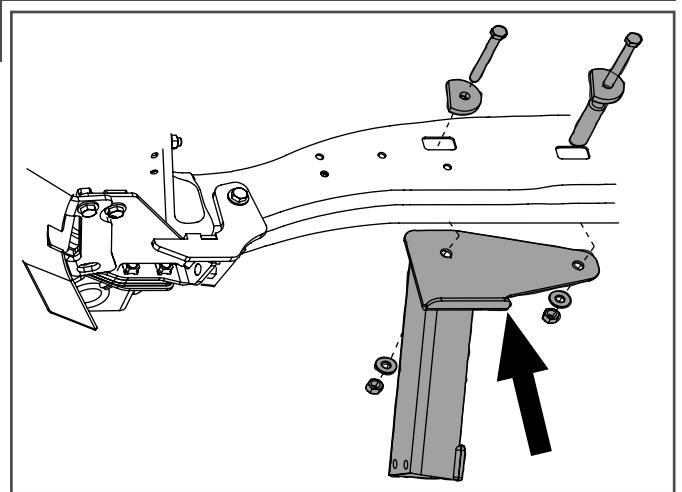

STEP 46

- Loosely install LH rearward wing mount, ITEM 11, using 2x M10 nuts, 1x M10X30 bolt & 3x M10 washers, ITEMS 60, 57 & 61, as shown.
- Do not tighten bolts yet.

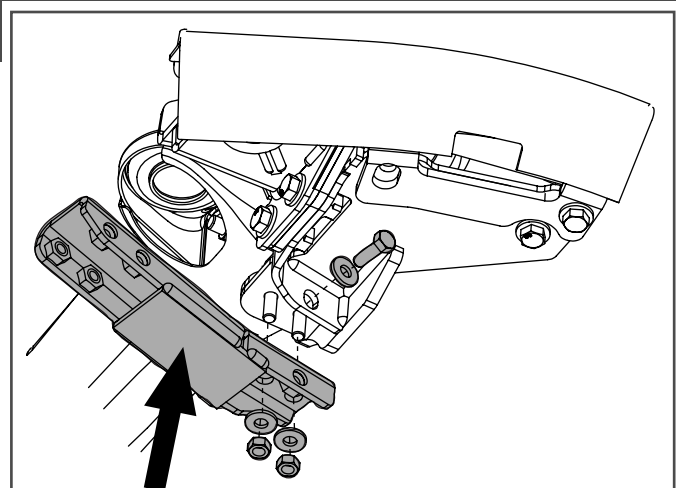

STEP 47

- Repeat steps 42 & 43 for RH side.

Note: The fuel filter will need to be temporarily removed to allow access for the RH forward wing mount. This can be achieved by removing the 3x 12mm head bolts. The fuel filter should be left off until the RH wing installation is complete.

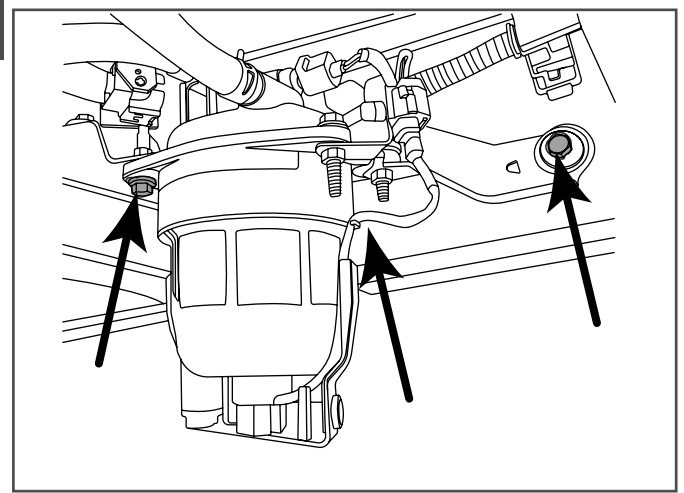

STEP 48

- Using a sharp knife, trim away the area shown on the LH mud flap. Test assemble the LH mud flap to the LH wing, ITEM 20, and if required trim further material away until mudflap is a good fit.

- Once final cut/position is achieved, install with 2x M6 bolts & 2x M6 nuts, ITEMS 62, 64 & 63, as shown. - Repeat for RH side.

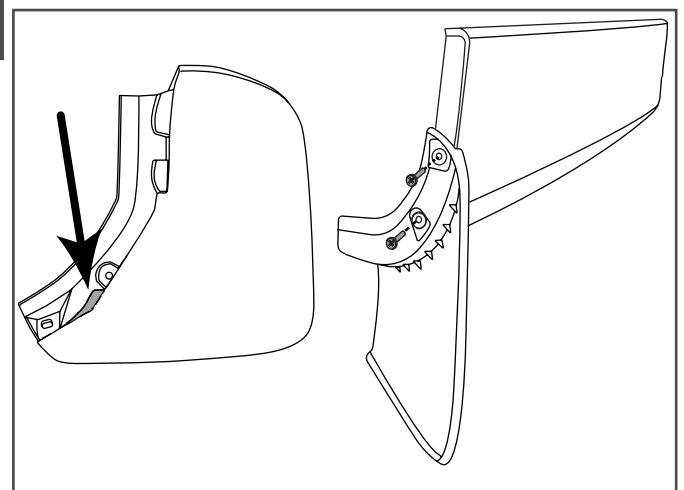

STEP 49

- Loosely assemble the LH wing to the LH forward & rearward mounts using 4x M12X30 bolts, 4x M12 washers, 4x M10X30 bolts & 4x M10 washers, ITEMS 51, 56, 57 & 61, as shown.

- Manipulate the position of the wing to achieve the best alignment with the swing arm & lower lip and begin to tighten the fasteners.

- Ensure a sufficient gap to the swing arm is maintained to allow it to open without contact.

- Once a suitable position is achieved, tighten M12 bolts to 90Nm & M10 bolts to 60Nm.

- Re-install the LH inner wheel lining and ensure the top edge is sitting behind mudflap as shown. This may require you to cut a small notch in the wheel liner to clear the upper edge of the wing.

- Repeat for RH side & reinstall fuel filter.

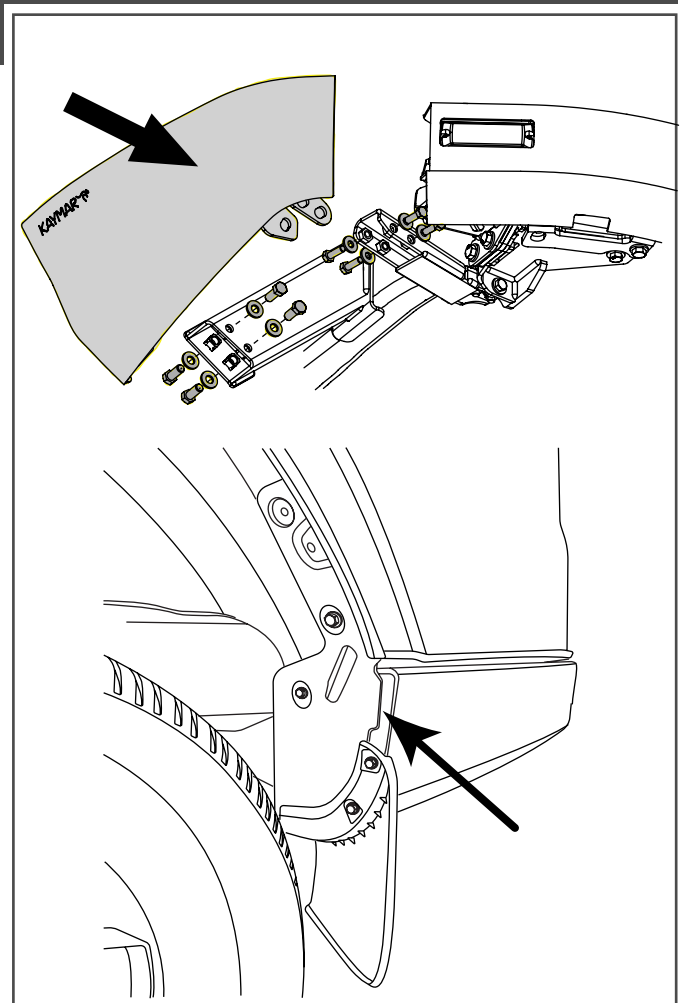

STEP 50

- Locate the supplied cut template, ITEM 44, on the LH side of the bumper and mark the cut line with a suitable masking tape. Repeat this for the RH side.
- Continue the masking line along the rear of the bumper using the bumper feature line as a height guide. This line should line up with the top edge of the inboard park sensor holes.
- Cut the bumper along the marked line using a suitable tool and clean up any edge burrs. Test fit the bumper.
- NOTE: The provided cut template will produce a tight bumper fitment designed to allow sufficient material for you to adjust to suit your specific installation.
- Mark out a new cut line with tape that provides between 10-15mm of clearance and follows the rear bar top surface shape.
- Remove & re-cut the bumper along this new line
- Repeat this process until you are happy with the clearance

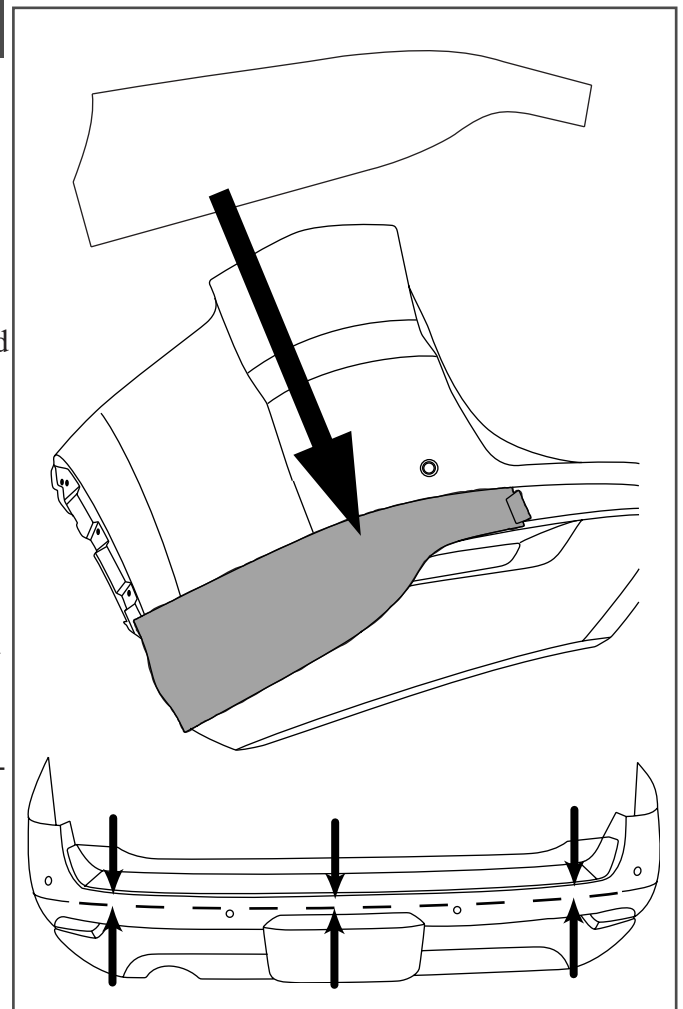

STEP 51

- Once a suitable bumper cut has been achieved, remove the bumper and install the supplied pinch weld.
- Leave excess pinch weld and the LH & RH ends to cover the wheel arch trims.

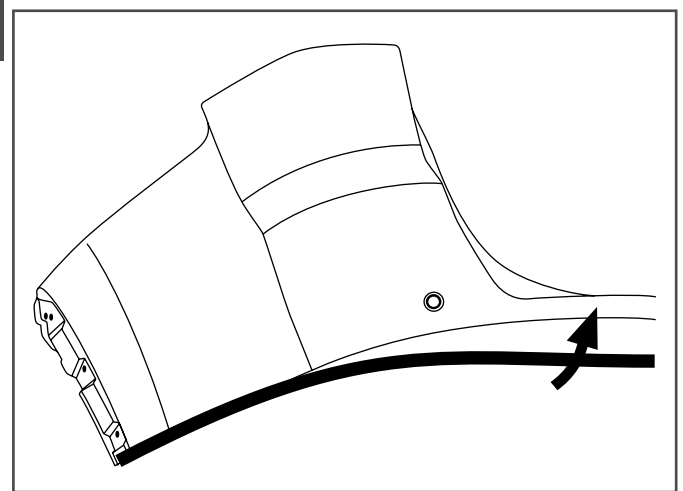

STEP 52

- Sit the LH wheel arch trim in place and mark a suitable line to cut that matches the bumper cut line.
- Remove & cut the LH wheel arch trim with a suitable tool. Repeat for the RH side.
- Continue the bumper pinch weld onto the wheel arch trim cut edge. The inboard side of the pinch weld will need to be notched to allow it transition onto the wheel arch trim.

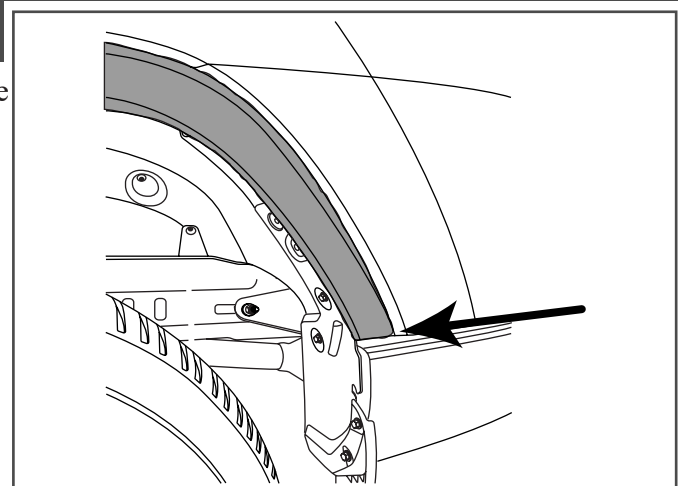

STEP 53

- Install the supplied foam blocks, ITEM 38 as shown to LH & RH vents to support the bumper.
- Offer the bumper to the vehicle and reconnect the out-board park sensors.
- Reinstall the bumper onto the vehicle and refit the screws, scrivenets & tail light covers, removed in steps 4 & 7.

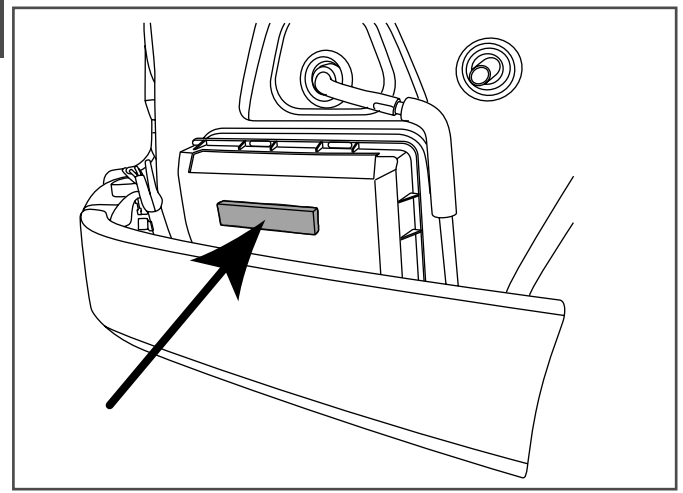

STEP 54

- From the underside of the step tread, remove 10mm from each of the 6 guide fins.
- Refit the step tread & spare wheel lowering rod cover
- Reinstall the cut wheel arch trims with scrivenets & screws removed in step 1.

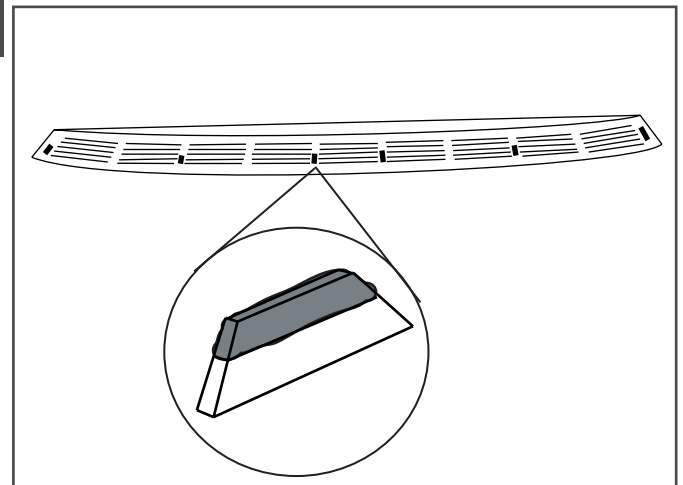

STEP 55

- Install the LH mud flap support, ITEM 29, to the wheel lining mounts using 2 of the bumper screws removed in step 2.
- Secure the mud flap to the support with 2x M6 bolts & 2x M6 nuts, ITEMS 62 & 63
- Secure the support to the wing mount with 2x tex screws, ITEM 67.
- Repeat for RH side.

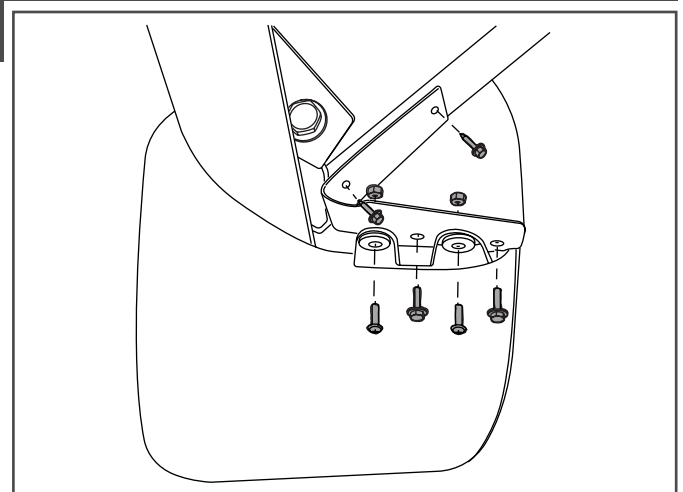

STEP 56

- Open the drivers door and install the supplied door rating label, ITEM 45, onto the B-pillar.

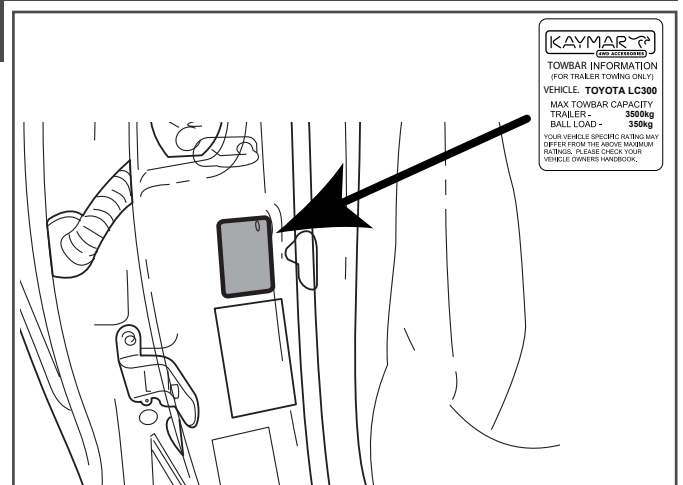

STEP 57

- Two adhesive reflectors, ITEM 37, are provided to replace the rear LH & RH ones removed with the lower portion of the bumper. They can be applied to the swing arm, wing, lower lip, bumper or carrier as preferred to ensure visibility from behind the vehicle. Ensure the area is clean before applying the reflector.

STEP 58

- A reflective triangle, ITEM 36, is provided to assist in alerting road users to the presence of the vehicle when opening the carriers on the road side. The triangle should be stored in a suitable place in the vehicle.